

AREA OF POLYGONS AND COMPLEX FIGURES

Area is the number of non-overlapping square units needed to cover the interior region of a two-dimensional figure or the surface area of a three-dimensional figure. For example, area is the region that is covered by floor tile (two-dimensional) or paint on a box or a ball (three-dimensional).

For additional information about specific shapes, see the boxes below. For additional general information, see the Math Notes box in Lesson 1.1.2 of the *Core Connections, Course 2* text. For additional examples and practice, see the *Core Connections, Course 2* Checkpoint 1 materials or the *Core Connections, Course 3* Checkpoint 4 materials.

AREA OF A RECTANGLE

To find the area of a rectangle, follow the steps below.

1. Identify the base.
2. Identify the height.
3. Multiply the base times the height to find the area in square units: $A = bh$.

A square is a rectangle in which the base and height are of equal length. Find the area of a square by multiplying the base times itself: $A = b^2$.

Example

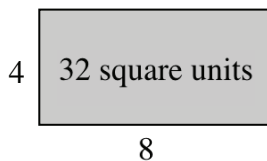

base = 8 units

height = 4 units

$$A = 8 \cdot 4 = 32 \text{ square units}$$

Problems

Find the areas of the rectangles (figures 1-8) and squares (figures 9-12) below.

1.

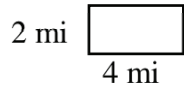

2.

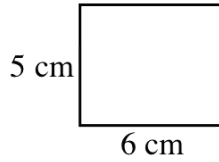

3.

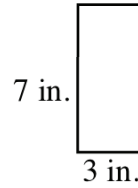

4.

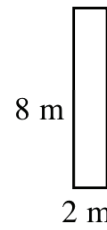

5.

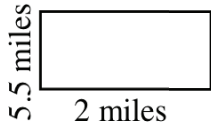

6.

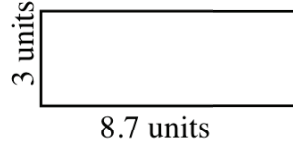

7.

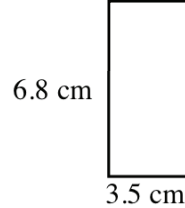

8.

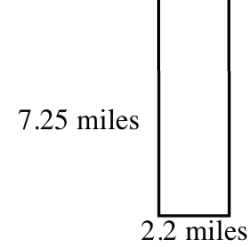

9.

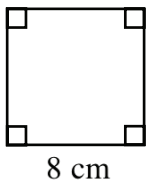

10.

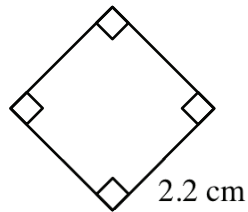

11.

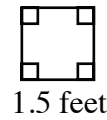

12.

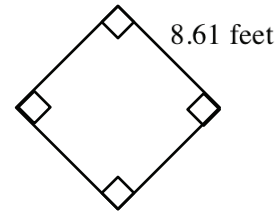

Answers

1. 8 sq. miles

2. 30 sq. cm

3. 21 sq. in.

4. 16 sq. m

5. 11 sq. miles

6. 26.1 sq. feet

7. 23.8 sq. cm

8. 15.95 sq. miles

9. 64 sq. cm

10. 4.84 sq. cm

11. 2.25 sq. feet

12. 73.96 sq. feet

AREA OF A PARALLELOGRAM

A parallelogram is easily changed to a rectangle by separating a triangle from one end of the parallelogram and moving it to the other end as shown in the three figures below. For additional information, see the Math Notes box in Lesson 5.3.3 of the *Core Connections, Course 1* text.

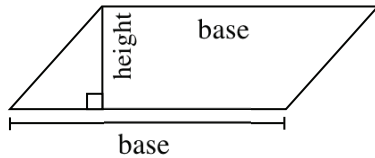

parallelogram
Step 1

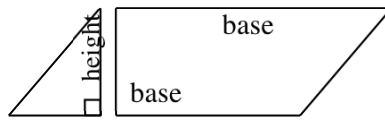

move triangle
Step 2

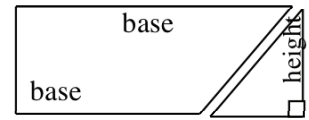

rectangle
Step 3

To find the area of a parallelogram, multiply the base times the height as you did with the rectangle: $A = bh$.

Example

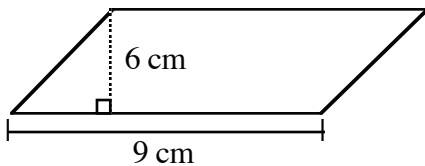

base = 9 cm

height = 6 cm

$A = 9 \cdot 6 = 54$ square cm

Problems

Find the area of each parallelogram below.

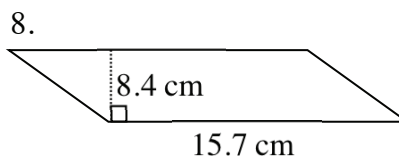
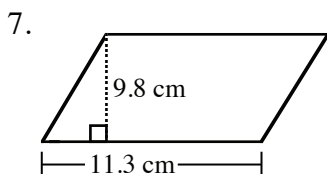
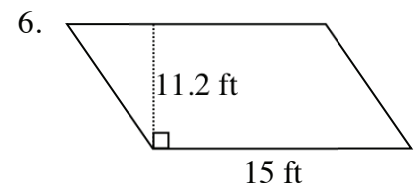
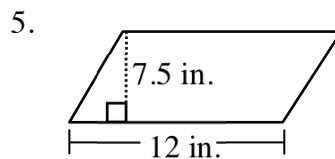
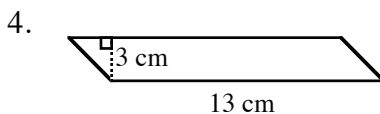
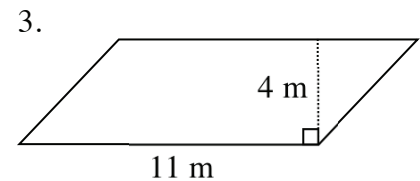
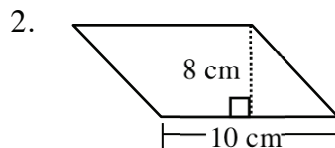
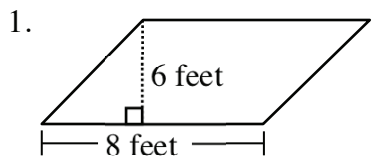

Answers

- | | | | |
|----------------|---------------|------------------|------------------|
| 1. 48 sq. feet | 2. 80 sq. cm | 3. 44 sq. m | 4. 39 sq. cm |
| 5. 90 sq. in. | 6. 168 sq. ft | 7. 110.74 sq. cm | 8. 131.88 sq. cm |

AREA OF A TRIANGLE

The area of a triangle is equal to one-half the area of a parallelogram. This fact can easily be shown by cutting a parallelogram in half along a diagonal (see below). For additional information, see Math Notes box in Lesson 5.3.4 of the *Core Connections, Course 1* text.

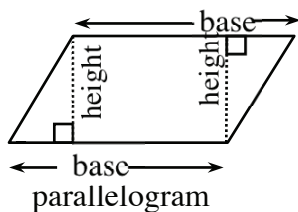

Step 1

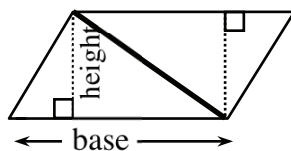

Step 2

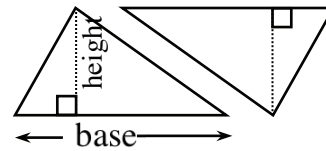

match triangles by cutting apart
or by folding

Step 3

As you match the triangles by either cutting the parallelogram apart or by folding along the diagonal, the result is two congruent (same size and shape) triangles. Thus, the area of a triangle has half the area of the parallelogram that can be created from two copies of the triangle.

To find the area of a triangle, follow the steps below.

1. Identify the base.
2. Identify the height.
3. Multiply the base times the height.
4. Divide the product of the base times the height by 2: $A = \frac{bh}{2}$ or $\frac{1}{2}bh$.

Example 1

base = 16 cm

height = 8 cm

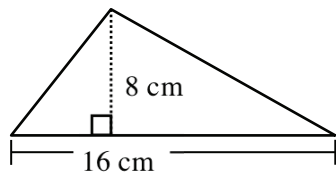

$$A = \frac{16 \cdot 8}{2} = \frac{128}{2} = 64\text{cm}^2$$

Example 2

base = 7 cm

height = 4 cm

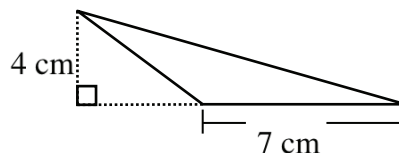

$$A = \frac{7 \cdot 4}{2} = \frac{28}{2} = 14\text{cm}^2$$

Problems

1.

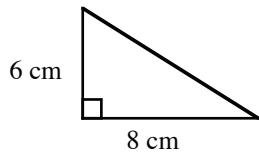

2.

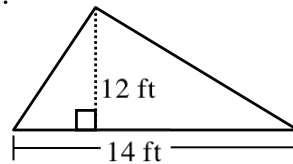

3.

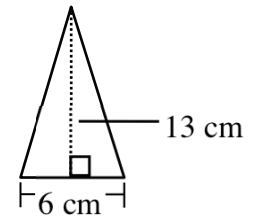

4.

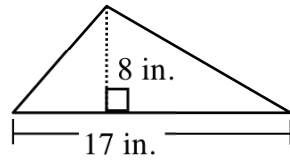

5.

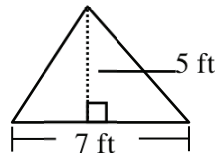

6.

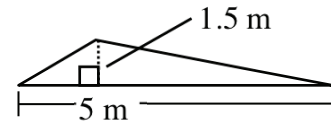

7.

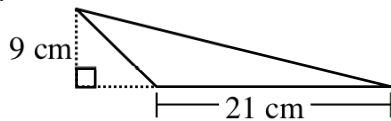

8.

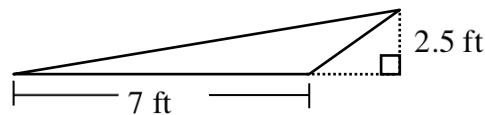

Answers

- | | | | |
|----------------|---------------|----------------|----------------|
| 1. 24 sq. cm | 2. 84 sq. ft | 3. 39 sq. cm | 4. 68 sq. in. |
| 5. 17.5 sq. ft | 6. 3.75 sq. m | 7. 94.5 sq. cm | 8. 8.75 sq. ft |

AREA OF A TRAPEZOID

A trapezoid is another shape that can be transformed into a parallelogram. Change a trapezoid into a parallelogram by following the three steps below.

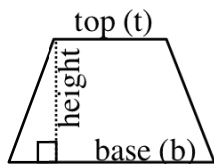

Trapezoid

Step 1

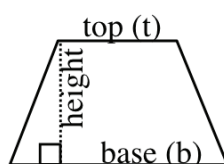

duplicate the trapezoid and rotate

Step 2

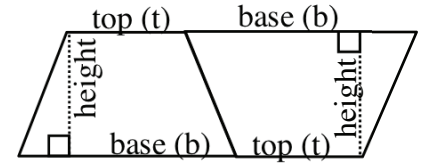
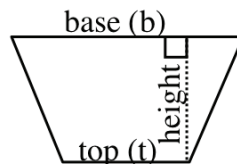

put the two trapezoids together to form a parallelogram

Step 3

To find the area of a trapezoid, multiply the base of the large parallelogram in Step 3 (base and top) times the height and then take half of the total area. Remember to add the lengths of the base and the top of the trapezoid before multiplying by the height. Note that some texts call the top length the upper base and the base the lower base.

$$A = \frac{1}{2} (b + t)h \quad \text{or} \quad A = \frac{b + t}{2} \cdot h$$

For additional information, see the Math Notes box in Lesson 6.1.1 of the *Core Connections, Course 1* text.

Example

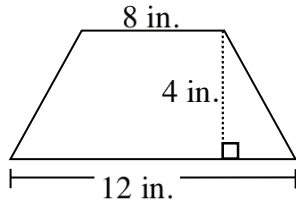

top = 8 in.

base = 12 in.

height = 4 in.

$$A = \frac{8+12}{2} \cdot 4 = \frac{20}{2} \cdot 4 = 10 \cdot 4 = 40 \text{ in.}^2$$

Problems

Find the areas of the trapezoids below.

1.

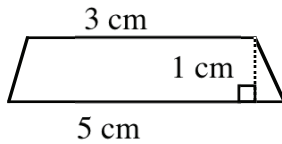

2.

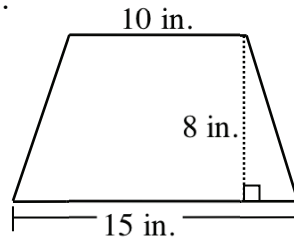

3.

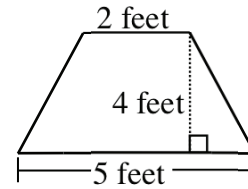

4.

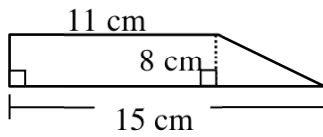

5.

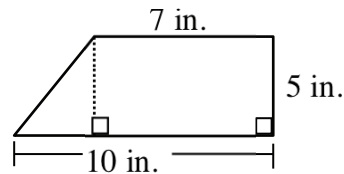

6.

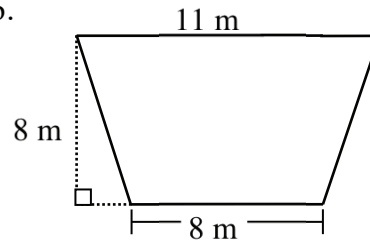

7.

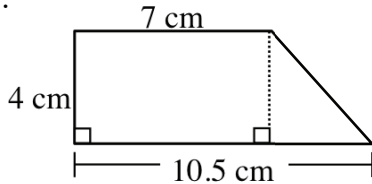

8.

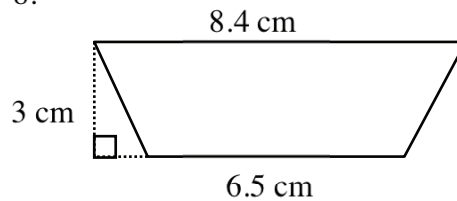

Answers

1. 4 sq. cm

2. 100 sq. in.

3. 14 sq. feet

4. 104 sq. cm

5. 42.5 sq. in.

6. 76 sq. m

7. 35 sq. cm

8. 22.35 sq. cm.

CALCULATING COMPLEX AREAS USING SUBPROBLEMS

Students can use their knowledge of areas of polygons to find the areas of more complicated figures. The use of subproblems (that is, solving smaller problems in order to solve a larger problem) is one way to find the areas of complicated figures.

Example 1

Find the area of the figure at right.

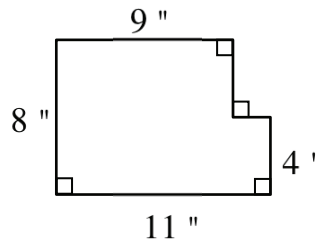

Method #1

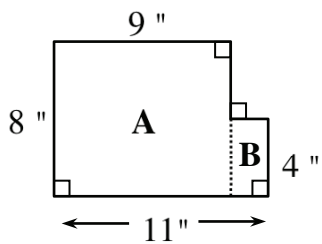

Subproblems:

1. Find the area of rectangle A:
 $8 \cdot 9 = 72$ square inches
2. Find the area of rectangle B:
 $4 \cdot (11 - 9) = 4 \cdot 2 = 8$ square inches
3. Add the area of rectangle A to the area of rectangle B:
 $72 + 8 = 80$ square inches

Method #2

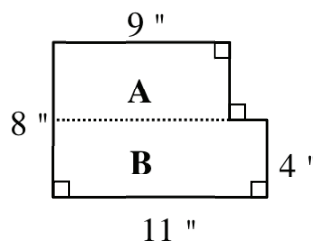

Subproblems:

1. Find the area of rectangle A:
 $9 \cdot (8 - 4) = 9 \cdot 4 = 36$ square inches
2. Find the area of rectangle B:
 $11 \cdot 4 = 44$ square inches
3. Add the area of rectangle A to the area of rectangle B:
 $36 + 44 = 80$ square inches

Method #3

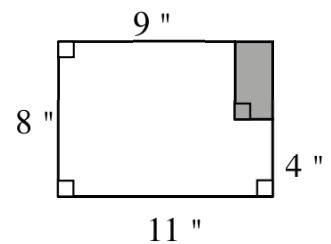

Subproblems:

1. Make a large rectangle by enclosing the upper right corner.
2. Find the area of the new, larger rectangle:
 $8 \cdot 11 = 88$ square inches
3. Find the area of the shaded rectangle:
 $(8 - 4) \cdot (11 - 9)$
 $= 4 \cdot 2 = 8$ square inches
4. Subtract the shaded rectangle from the larger rectangle:
 $88 - 8 = 80$ square inches

Example 2

Find the area of the figure at right.

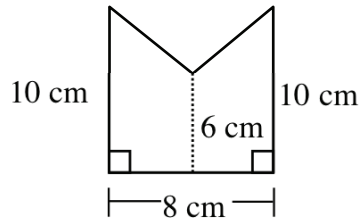

Subproblems:

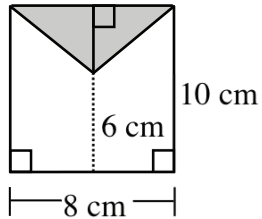

1. Make a rectangle out of the figure by enclosing the top.
2. Find the area of the entire rectangle: $8 \cdot 10 = 80$ square cm
3. Find the area of the shaded triangle. Use the formula $A = \frac{1}{2}bh$. $b = 8$ and $h = 10 - 6 = 4$, so $A = \frac{1}{2}(8 \cdot 4) = \frac{32}{2} = 16$ square cm.
4. Subtract the area of the triangle from the area of the rectangle: $80 - 16 = 64$ square cm.

Problems

Find the areas of the figures below.

1.

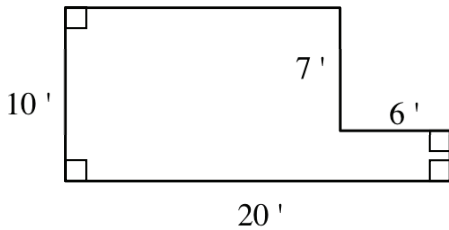

2.

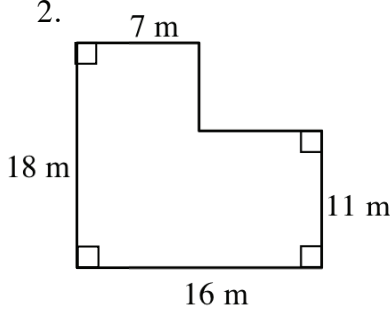

3.

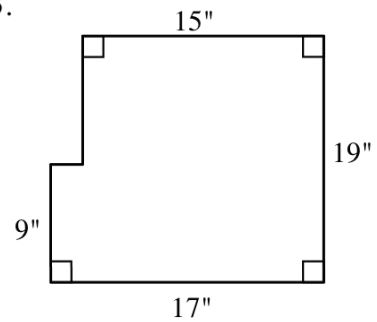

4.

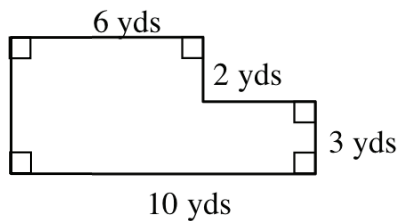

5.

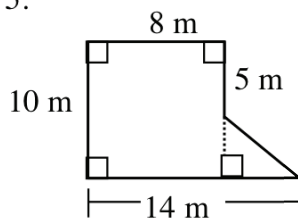

6.

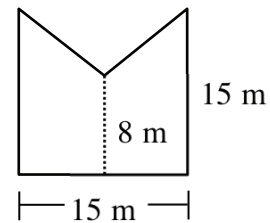

7.

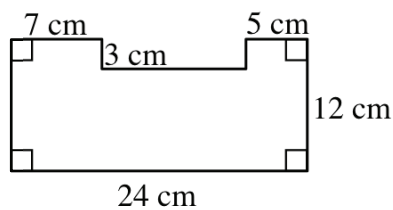

8.

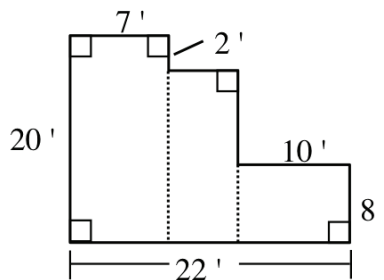

9.

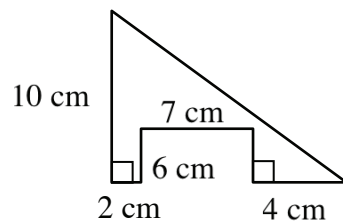

10.

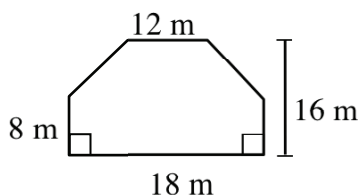

11. Find the area of the shaded region.

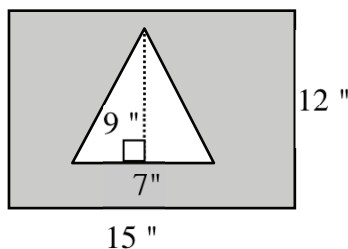

12. Find the area of the shaded region.

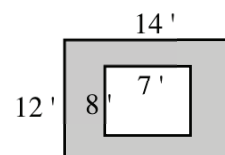

Answers

- | | | | |
|----------------|-----------------|-------------------|-----------------|
| 1. 158 sq. ft. | 2. 225 sq. m. | 3. 303 sq. in. | 4. 42 sq. yd. |
| 5. 95 sq. m. | 6. 172.5 sq. m. | 7. 252 sq. cm. | 8. 310 sq. ft. |
| 9. 23 sq. cm. | 10. 264 sq. m. | 11. 148.5 sq. in. | 12. 112 sq. ft. |

PRISMS – VOLUME AND SURFACE AREA

SURFACE AREA OF A PRISM

The surface area of a prism is the sum of the areas of all of the faces, including the bases. Surface area is expressed in square units.

For additional information, see the Math Notes boxes in Lessons 9.2.1 and 9.2.2 of the *Core Connections, Course 1* text and Lesson 9.2.4 of the *Core Connections, Course 2* text.

Example

Find the surface area of the triangular prism at right.

Step 1: Area of the 2 bases: $2 \left[\frac{1}{2} (6 \text{ cm})(8 \text{ cm}) \right] = 48 \text{ cm}^2$

Step 2: Area of the 3 lateral faces

Area of face 1: $(6 \text{ cm})(7 \text{ cm}) = 42 \text{ cm}^2$
 Area of face 2: $(8 \text{ cm})(7 \text{ cm}) = 56 \text{ cm}^2$
 Area of face 3: $(10 \text{ cm})(7 \text{ cm}) = 70 \text{ cm}^2$

Step 3: Surface Area of Prism = sum of bases and lateral faces:

$SA = 48 \text{ cm}^2 + 42 \text{ cm}^2 + 56 \text{ cm}^2 + 70 \text{ cm}^2 = 216 \text{ cm}^2$

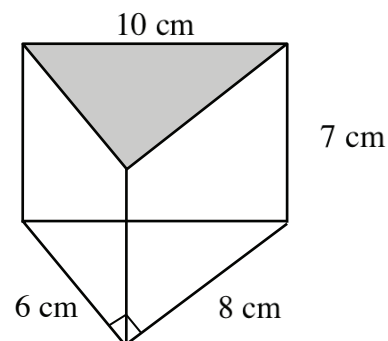

Problems

Find the surface area of each prism.

1.

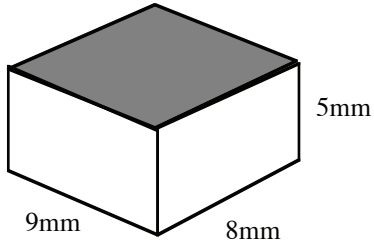

2.

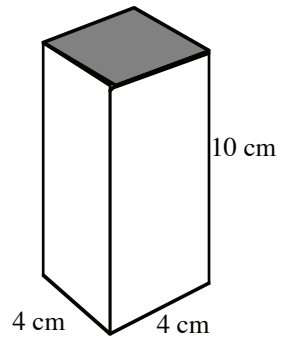

3.

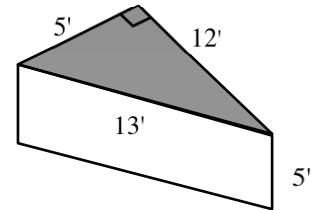

4.

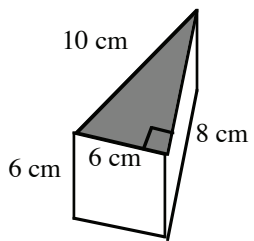

5. The pentagon is equilateral.

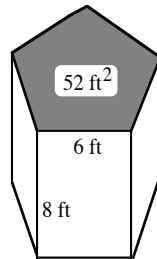

6.

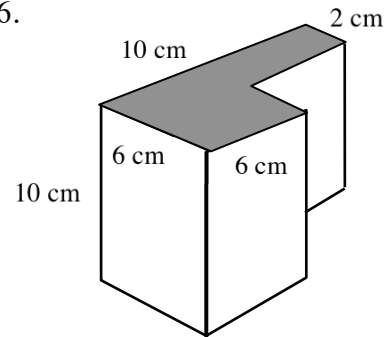

Answers

1. 314 mm^2

2. 192 cm^2

3. 210 ft^2

4. 192 cm^2

5. 344 ft^2

6. 408 cm^2

VOLUME OF A PRISM

Volume is a three-dimensional concept. It measures the amount of interior space of a three-dimensional figure based on a cubic unit, that is, the number of 1 by 1 by 1 cubes that will fit inside a figure.

The volume of a prism is the area of either base (B) multiplied by the height (h) of the prism.

$$V = (\text{Area of base}) \cdot (\text{height}) \text{ or } V = Bh$$

For additional information, see the Math Notes boxes in Lesson 9.2.1 of the *Core Connections, Course 1* text and Lesson 9.2.4 of the *Core Connections, Course 2* text.

Example 1

Find the volume of the square prism below.

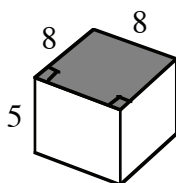

The base is a square with area (B)
 $8 \cdot 8 = 64 \text{ units}^2$.

$$\begin{aligned} \text{Volume} &= B(h) \\ &= 64(5) \\ &= 320 \text{ units}^3 \end{aligned}$$

Example 2

Find the volume of the triangular prism below.

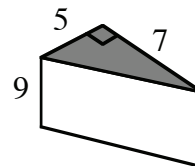

The base is a right triangle with area
 $\frac{1}{2}(5)(7) = 17.5 \text{ units}^2$.

$$\begin{aligned} \text{Volume} &= B(h) \\ &= 17.5(9) \\ &= 157.5 \text{ units}^3 \end{aligned}$$

Example 3

Find the volume of the trapezoidal prism below.

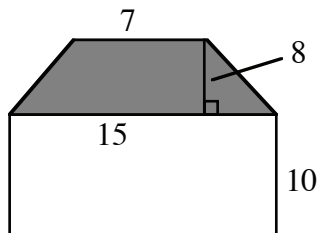

The base is a trapezoid with area
 $\frac{1}{2}(7 + 15) \cdot 8 = 88 \text{ units}^2$.

$$\begin{aligned} \text{Volume} &= B(h) \\ &= 88(10) \\ &= 880 \text{ units}^3 \end{aligned}$$

Example 4

Find the height of the prism with a volume of 132.5 cm^3 and base area of 25 cm^2 .

$$\begin{aligned} \text{Volume} &= B(h) \\ 132.5 &= 25(h) \\ h &= \frac{132.5}{25} \\ h &= 5.3 \text{ cm} \end{aligned}$$

Problems

Calculate the volume of each prism. The base of each figure is shaded.

1. Rectangular Prism

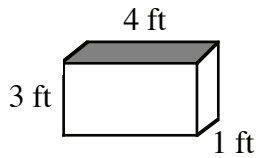

2. Right Triangular Prism

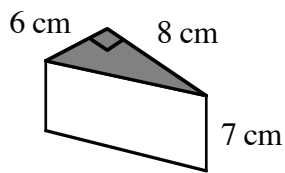

3. Rectangular Prism

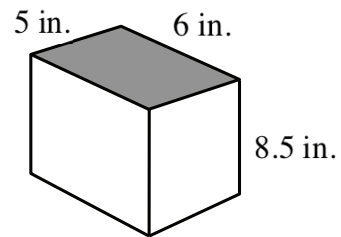

4. Right Triangular Prism

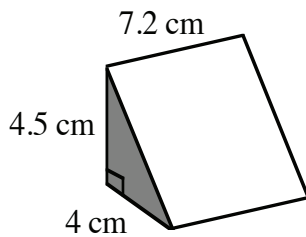

5. Trapezoidal Prism

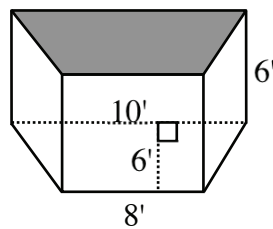

6. Triangular Prism with $B = 15\frac{1}{2} \text{ cm}^2$

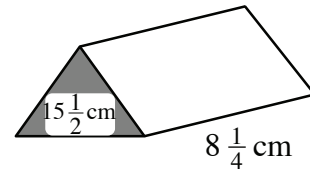

7. Find the volume of a prism with base area 32 cm^2 and height 1.5 cm .

8. Find the height of a prism with base area 32 cm^2 and volume 176 cm^3 .

9. Find the base area of a prism with volume 47.01 cm^3 and height 3.2 cm .

Answers

1. 12 ft^3 2. 168 cm^3 3. 240 in.^3 4. 64.8 cm^3 5. 324 ft^3

6. $127\frac{7}{8} \text{ cm}^3$ 7. 48 cm^3 8. 5.5 cm 9. 14.7 cm^2

NAMING QUADRILATERALS AND ANGLES

A quadrilateral is any four-sided polygon. There are six special cases of quadrilaterals with which students should be familiar.

- Trapezoid – A quadrilateral with at least one pair of parallel sides.
- Parallelogram – A quadrilateral with both pairs of opposite sides parallel.
- Rectangle – A quadrilateral with four right angles.
- Rhombus – A quadrilateral with four sides of equal length.
- Square – A quadrilateral with four right angles and four sides of equal length.
- Kite – A quadrilateral with two distinct pairs of consecutive sides of equal length.

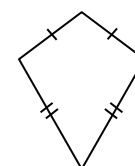
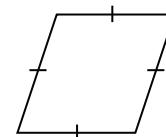
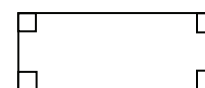
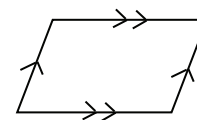
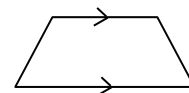

Names of Basic Angles

Acute angles are angles with measures between (but not including) 0° and 90° , right angles measure 90° , and obtuse angles measure between (but not including) 90° and 180° . A straight angle measures 180° .

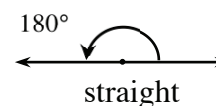
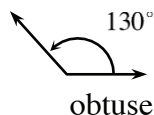
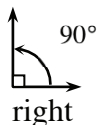
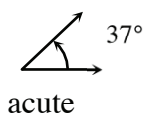

Students use protractors to measure the size of angles.

For more information see the Math Notes box in Lesson 8.3.1 of the *Core Connections, Course 2* text.

Example 1

For the figure at right, describe the quadrilateral using *all* terms that are appropriate.

It is a rectangle since it has four right angles.

It is a parallelogram since it has two pairs of parallel sides.

It is also a trapezoid since it has at least one pair of parallel sides.

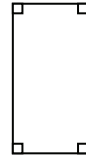

Example 2

Describe the angle at right as right, obtuse or acute. Estimate the size of the angle and then use a protractor to measure the angle. It may be necessary to trace the angle and extend the sides.

This angle opens narrower than a right angle so it is acute. Using a protractor shows that the angle measures 60° .

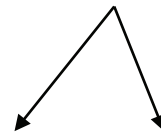

Problems

For each figure, describe the quadrilateral using *all* terms that are appropriate. Assume that sides that look parallel are parallel.

1.

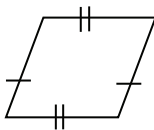

2.

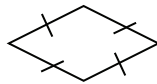

3.

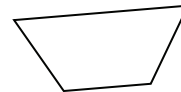

4.

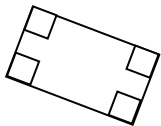

5.

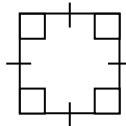

6.

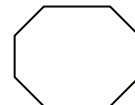

Describe the angles below as right, obtuse or acute. Estimate the size of the angle and then use a protractor to measure the angle.

7.

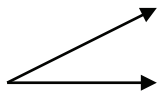

8.

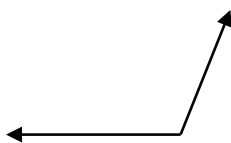

9.

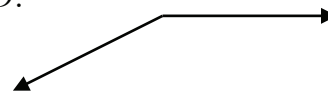

10.



11.

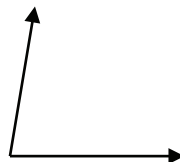

12.

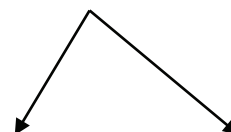

Answers

1. parallelogram,
trapezoid

2. rhombus,
parallelogram,
trapezoid

3. trapezoid

4. rectangle,
parallelogram,
trapezoid

5. square, rhombus,
rectangle,
parallelogram,
trapezoid

6. not a quadrilateral

7. acute, 25°

8. obtuse, 110°

9. obtuse, 153°

10. right, 90°

11. acute, 80°

12. acute, 82°

ANGLE PAIR RELATIONSHIPS

Properties of Angle Pairs

Intersecting lines form four angles. The pairs of angles across from each other are called vertical angles. The measures of vertical angles are equal.

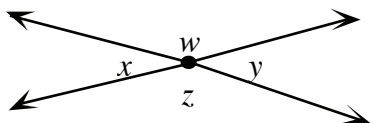

$\angle x$ and $\angle y$ are vertical angles
 $\angle w$ and $\angle z$ are vertical angles

If the sum of the measures of two angles is exactly 180° , then the angles are called supplementary angles.

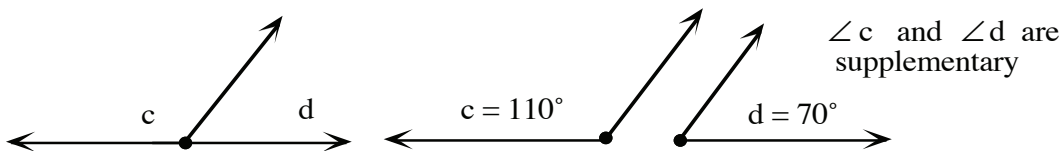

If the sum of the measures of two angles is exactly 90° , then the angles are called complementary angles.

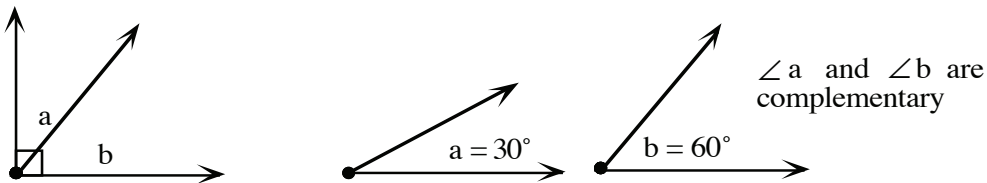

Angles that share a vertex and one side but have no common interior points (that is, do not overlap each other) are called adjacent angles.

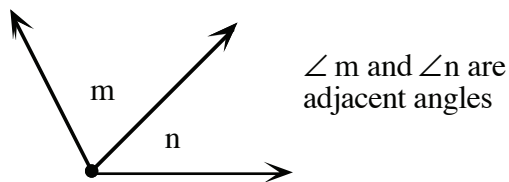

For additional information, see the Math Notes boxes in Lesson 8.3.2 of the *Core Connections, Course 2* text and Lesson 9.1.1 of the *Core Connections, Course 3* text.

Example 1

Find the measure of the missing angles if $m \angle 3 = 50^\circ$.

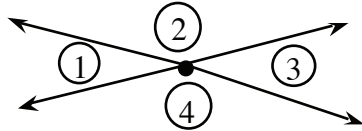

- $m \angle 1 = m \angle 3$ (vertical angles)
 $\Rightarrow m \angle 1 = 50^\circ$
- $\angle 2$ and $\angle 3$ (supplementary angles)
 $\Rightarrow m \angle 2 = 180^\circ - 50^\circ = 130^\circ$
- $m \angle 2 = m \angle 4$ (vertical angles)
 $\Rightarrow m \angle 4 = 130^\circ$

Example 2

Classify each pair of angles below as vertical, supplementary, complementary, or adjacent.

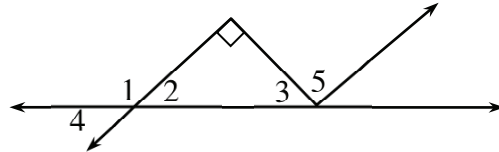

- a. $\angle 1$ and $\angle 2$ are adjacent and supplementary
- b. $\angle 2$ and $\angle 3$ are complementary
- c. $\angle 3$ and $\angle 5$ are adjacent
- d. $\angle 1$ and $\angle 4$ are adjacent and supplementary
- e. $\angle 2$ and $\angle 4$ are vertical

Problems

Find the measure of each angle labeled with a variable.

1.

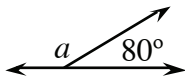

2.

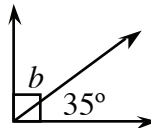

3.

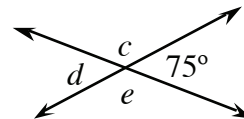

4.

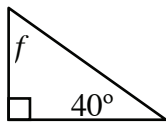

5.

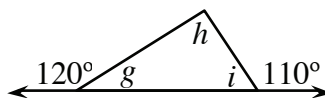

6.

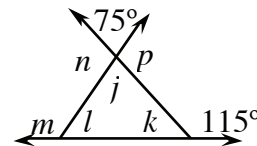

Answers

1. $m \angle a = 100^\circ$

2. $m \angle b = 55^\circ$

3. $m \angle c = 105^\circ$
 $m \angle d = 75^\circ$
 $m \angle e = 105^\circ$

4. $m \angle f = 50^\circ$

5. $m \angle g = 60^\circ$
 $m \angle h = 50^\circ$
 $m \angle i = 70^\circ$

6. $m \angle j = 75^\circ$ $m \angle k = 65^\circ$
 $m \angle l = 40^\circ$ $m \angle m = 140^\circ$
 $m \angle n = 105^\circ$ $m \angle p = 105^\circ$

PROPERTIES OF ANGLES, LINES, AND TRIANGLES

Students learn the relationships created when two parallel lines are intersected by a transversal. They also study angle relationships in triangles.

Parallel lines

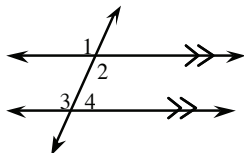

- corresponding angles are equal: $m\angle 1 = m\angle 3$
- alternate interior angles are equal: $m\angle 2 = m\angle 3$
- $m\angle 2 + m\angle 4 = 180^\circ$

- Also shown in the above figures:
- vertical angles are equal: $m\angle 1 = m\angle 2$
 - linear pairs are supplementary: $m\angle 3 + m\angle 4 = 180^\circ$ and $m\angle 6 + m\angle 7 = 180^\circ$

Triangles

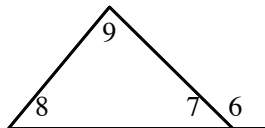

- $m\angle 7 + m\angle 8 + m\angle 9 = 180^\circ$
- $m\angle 6 = m\angle 8 + m\angle 9$
(exterior angle = sum remote interior angles)

In addition, an isosceles triangle, $\triangle ABC$, has $\overline{BA} = \overline{BC}$ and $m\angle A = m\angle C$. An equilateral triangle, $\triangle GFH$, has $\overline{GF} = \overline{FH} = \overline{HG}$ and $m\angle G = m\angle F = m\angle H = 60^\circ$.

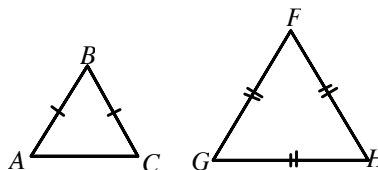

For more information, see the Math Notes boxes in Lessons 9.1.2, 9.1.3, and 9.1.4 of the *Core Connections, Course 3* text.

Example 1

Solve for x .

Use the Exterior Angle Theorem: $6x + 8^\circ = 49^\circ + 67^\circ$

$$6x^\circ = 108^\circ \Rightarrow x = \frac{108^\circ}{6} \Rightarrow x = 18^\circ$$

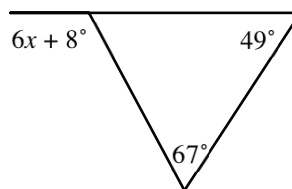

Example 2

Solve for x .

There are a number of relationships in this diagram. First, $\angle 1$ and the 127° angle are supplementary, so we know that $m\angle 1 + 127^\circ = 180^\circ$ so $m\angle 1 = 53^\circ$. Using the same idea, $m\angle 2 = 47^\circ$. Next, $m\angle 3 + 53^\circ + 47^\circ = 180^\circ$, so $m\angle 3 = 80^\circ$. Because angle 3 forms a vertical pair with the angle marked $7x + 3^\circ$, $80^\circ = 7x + 3^\circ$, so $x = 11^\circ$.

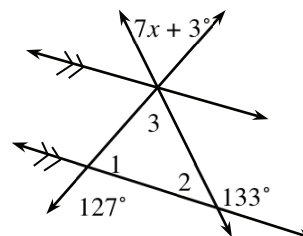

Example 3

Find the measure of the acute alternate interior angles.

Parallel lines mean that alternate interior angles are equal, so

$5x + 28^\circ = 2x + 46^\circ \Rightarrow 3x = 18^\circ \Rightarrow x = 6^\circ$. Use either algebraic angle measure: $2(6^\circ) + 46^\circ = 58^\circ$ for the measure of the acute angle.

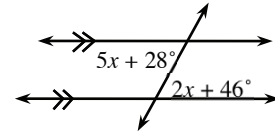

Problems

Use the geometric properties you have learned to solve for x in each diagram and write the property you use in each case.

1.

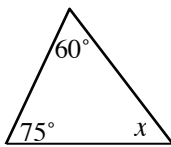

2.

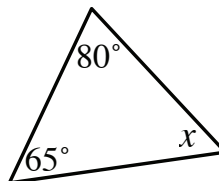

3.

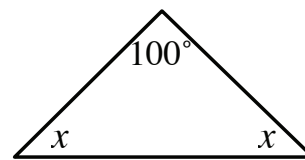

4.

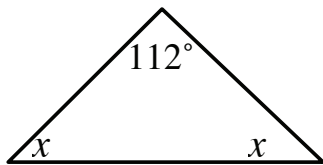

5.

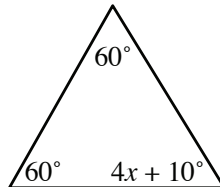

6.

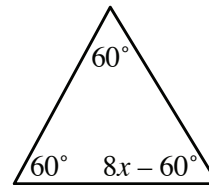

7.

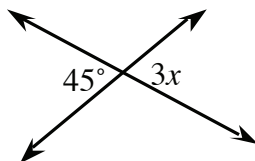

8.

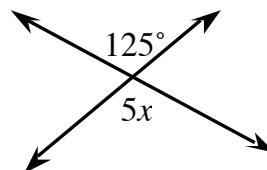

9.

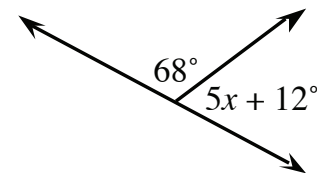

10.

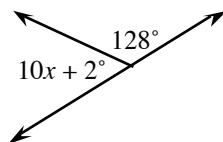

11.

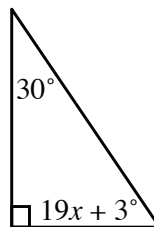

12.

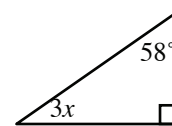

13.

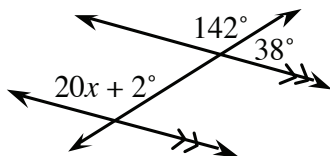

14.

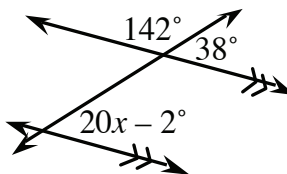

15.

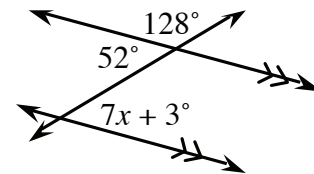

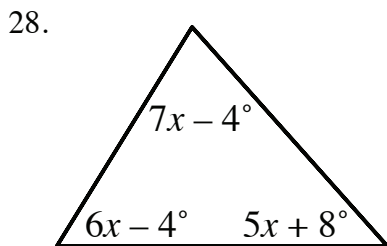
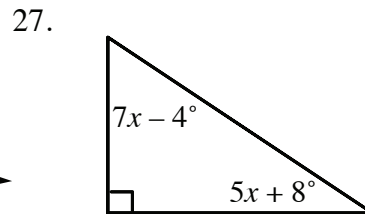
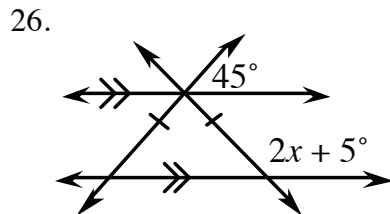
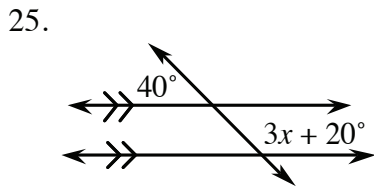
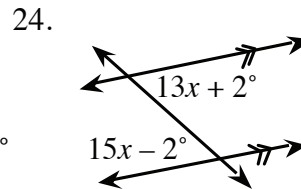
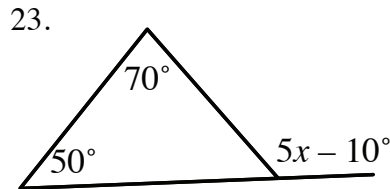
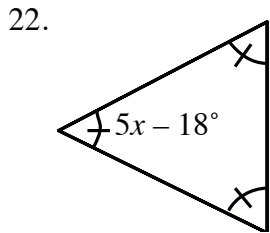
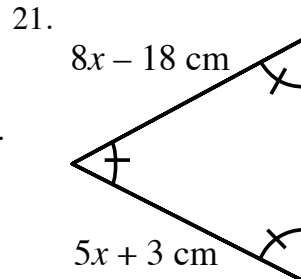
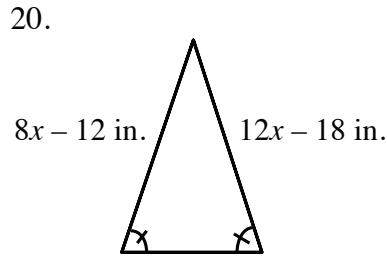
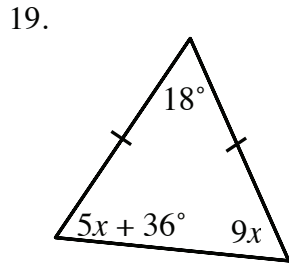
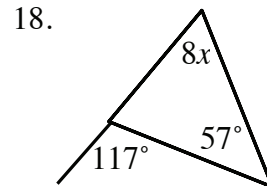
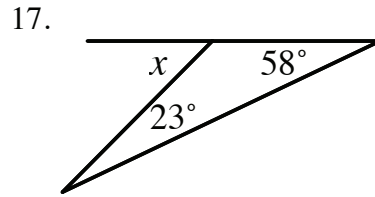
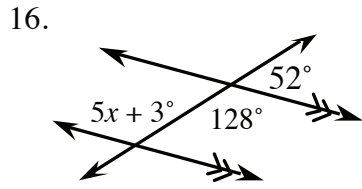

Answers

- | | | | | | |
|---------|----------|----------------------|-----------|----------|-----------------------|
| 1. 45° | 2. 35° | 3. 40° | 4. 34° | 5. 12.5° | 6. 15° |
| 7. 15° | 8. 25° | 9. 20° | 10. 5° | 11. 3° | 12. $10\frac{2}{3}$ ° |
| 13. 7° | 14. 2° | 15. 7° | 16. 25° | 17. 81° | 18. 7.5° |
| 19. 9° | 20. 7.5° | 21. 7° | 22. 15.6° | 23. 26° | 24. 2° |
| 25. 40° | 26. 65° | 27. $7\frac{1}{6}$ ° | 28. 10° | | |

CIRCLES – CIRCUMFERENCE AND AREA

CIRCUMFERENCE

The radius of a circle is a line segment from its center to any point on the circle. The term is also used for the length of these segments. More than one radius are called radii. A chord of a circle is a line segment joining any two points on a circle. A diameter of a circle is a chord that goes through its center. The term is also used for the length of these chords. The length of a diameter is twice the length of a radius.

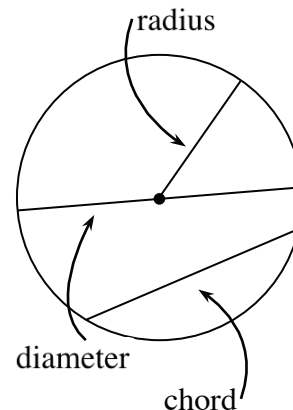

The circumference of a circle is similar to the perimeter of a polygon. The circumference is the length of a circle. The circumference would tell you how much string it would take to go around a circle once.

Circumference is explored by investigating the ratio of the circumference to the diameter of a circle. This ratio is a constant number, pi (π). Circumference is then found by multiplying π by the diameter. Students may use $\frac{22}{7}$, 3.14, or the π button on their calculator, depending on the teacher's or the book's directions.

$$C = 2\pi r \quad \text{or} \quad C = \pi d$$

For additional information, see the Math Notes boxes in Lessons 8.3.3 and 9.1.2 of the *Core Connections, Course 2* text or Lesson 3.2.2 of the *Core Connections, Course 3* text. For additional examples and practice, see the *Core Connections, Course 3* Checkpoint 4 materials.

Example 1

Find the circumference of a circle with a diameter of 5 inches.

$$d = 5 \text{ inches}$$

$$\begin{aligned} C &= \pi d \\ &= \pi(5) \text{ or } 3.14(5) \\ &= 15.7 \text{ inches} \end{aligned}$$

Example 2

Find the circumference of a circle with a radius of 10 units.

$$r = 10, \text{ so } d = 2(10) = 20$$

$$\begin{aligned} C &= 3.14(20) \\ &= 62.8 \text{ units} \end{aligned}$$

Example 3

Find the diameter of a circle with a circumference of 163.28 inches.

$$\begin{aligned} C &= \pi d \\ 163.28 &= \pi d \\ 163.28 &= 3.14d \\ d &= \frac{163.28}{3.14} \\ &= 52 \text{ inches} \end{aligned}$$

Problems

Find the circumference of each circle given the following radius or diameter lengths. Round your answer to the nearest hundredth.

1. $d = 12$ in. 2. $d = 3.4$ cm 3. $r = 2.1$ ft 4. $d = 25$ m 5. $r = 1.54$ mi

Find the circumference of each circle shown below. Round your answer to the nearest hundredth.

6.

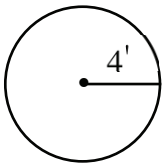

7.

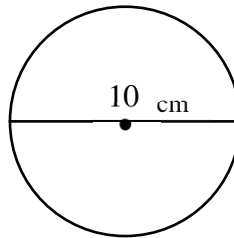

Find the diameter of each circle given the circumference. Round your answer to the nearest tenth.

8. $C = 48.36$ yds 9. $C = 35.6$ ft 10. $C = 194.68$ mm

Answers

1. 37.68 in. 2. 10.68 cm. 3. 13.19 ft 4. 78.5 m
5. 9.67 mi 6. 25.12 ft 7. 31.40 cm 8. 15.4 yds
9. 11.3 ft 10. 62 mm

AREA OF A CIRCLE

In class, students have done explorations with circles and circular objects to discover the relationship between circumference, diameter, and pi (π). To read more about the in-class exploration of area, see problems 9-22 through 9-26 (especially 9-26) in the *Core Connections, Course 2* text.

In order to find the area of a circle, students need to identify the radius of the circle. The radius is half the diameter. Next they will square the radius and multiply the result by π . Depending on the teacher's or book's preference, students may use $\frac{22}{7}$ for π when the radius or diameter is a fraction, 3.14 for π as an approximation, or the π button on a calculator. When using the π button, most teachers will want students to round to the nearest tenth or hundredth.

The formula for the area of a circle is: $A = r^2\pi$.

Example 1

Find the area of a circle with $r = 17$ feet.

$$\begin{aligned} A &= (17)^2 \pi \\ &= (17 \cdot 17) (3.14) \\ &= 907.46 \text{ square feet} \end{aligned}$$

Example 2

Find the area of a circle with $d = 84$ cm.

$$\begin{aligned} r &= 42 \text{ cm} \\ A &= (42)^2 \pi \\ &= (42 \cdot 42) (3.14) \\ &= 5538.96 \text{ square cm} \end{aligned}$$

Problems

Find the area of the circles with the following radius or diameter lengths. Use 3.14 for the value of π . Round to the nearest hundredth.

- | | | | |
|-------------------------|-------------------|-----------------|---------------------------|
| 1. $r = 6$ cm | 2. $r = 3.2$ in. | 3. $d = 16$ ft | 4. $r = \frac{1}{2}$ m |
| 5. $d = \frac{4}{5}$ cm | 6. $r = 5$ in. | 7. $r = 3.6$ cm | 8. $r = 2\frac{1}{4}$ in. |
| 9. $d = 14.5$ ft | 10. $r = 12.02$ m | | |

Answers

- | | | |
|-----------------------------------|---|---------------------------|
| 1. 113.04 cm ² | 2. 32.15 in. ² | 3. 200.96 ft ² |
| 4. $\frac{11}{14}$ m ² | 5. $\frac{88}{175}$ cm ² | 6. 78.5 in. ² |
| 7. 40.69 cm ² | 8. $15\frac{51}{56}$ or 15.90 in ² | 9. 165.05 ft ² |
| 10. 453.67 m ² | | |

RIGID TRANSFORMATIONS

Studying transformations of geometric shapes builds a foundation for a key idea in geometry: congruence. In this introduction to transformations, the students explore three rigid motions: translations, reflections, and rotations. A translation slides a figure horizontally, vertically or both. A reflection flips a figure across a fixed line (for example, the x -axis). A rotation turns an object about a point (for example, $(0,0)$). This exploration is done with simple tools that can be found at home (tracing paper) as well as with computer software. Students change the position and/or orientation of a shape by applying one or more of these motions to the original figure to create its image in a new position without changing its size or shape. Transformations also lead directly to studying symmetry in shapes. These ideas will help with describing and classifying geometric shapes later in the course.

For additional information, see the Math Notes box in Lesson 6.1.3 of the *Core Connections, Course 3* text.

Example 1

Decide which transformation was used on each pair of shapes below. Some may be a combination of transformations.

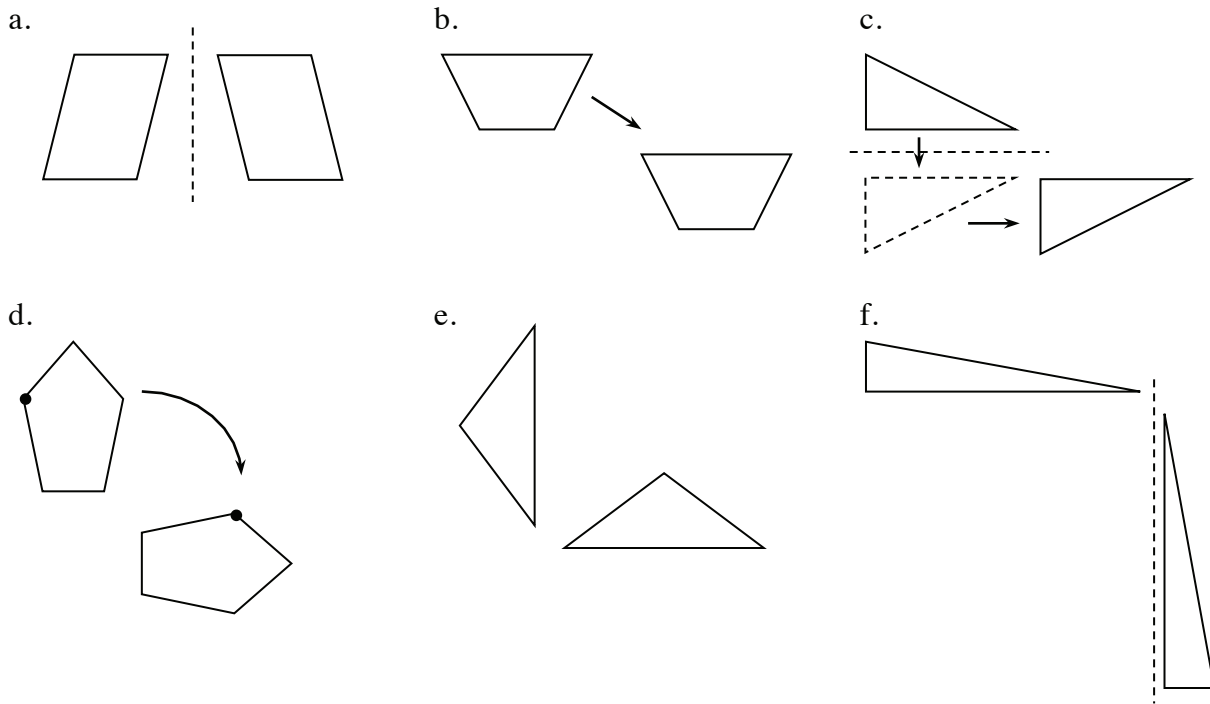

Identifying a single transformation is usually easy for students. In part (a), the parallelogram is reflected (flipped) across an invisible vertical line. (Imagine a mirror running vertically between the two figures. One figure would be the reflection of the other.) Reflecting a shape once changes its orientation, that is, how its parts “sit” on the flat surface. For example, in part (a), the two sides of the figure at left slant upwards to the right, whereas in its reflection at right, they slant upwards to the left. Likewise, the angles in the figure at left “switch positions” in the figure at right.

In part (b), the shape is translated (or slid) to the right and down. The orientation is the same. Part (c) shows a combination of transformations. First the triangle is reflected (flipped) across an invisible horizontal line. Then it is translated (slid) to the right. The pentagon in part (d) has been rotated (turned) clockwise to create the second figure. Imagine tracing the first figure on tracing paper, then holding the tracing paper with a pin at one point below the first pentagon, then turning the paper to the right (that is, clockwise) 90° . The second pentagon would be the result. Some students might see this as a reflection across a diagonal line. The pentagon itself could be, but with the added dot, the entire shape cannot be a reflection. If it had been reflected, the dot would have to be on the corner below the one shown in the rotated figure. The triangles in part (e) are rotations of each other (90° clockwise again). Part (f) shows another combination. The triangle is rotated (the horizontal side becomes vertical) but also reflected since the longest side of the triangle points in the opposite direction from the first figure.

Example 2

Translate (slide) $\triangle ABC$ right six units and up three units. Give the coordinates of the new triangle.

The original vertices are $A(-5, -2)$, $B(-3, 1)$, and $C(0, -5)$. The new vertices are $A'(1, 1)$, $B'(3, 4)$, and $C'(6, -2)$. Notice that the change to each original point (x, y) can be represented by $(x + 6, y + 3)$.

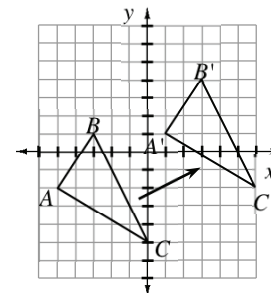

Example 3

Reflect (flip) $\triangle ABC$ with coordinates $A(5, 2)$, $B(2, 4)$, and $C(4, 6)$ across the y -axis to get $\triangle A'B'C'$. The key is that the reflection is the same distance from the y -axis as the original figure. The new points are $A'(-5, 2)$, $B'(-2, 4)$, and $C'(-4, 6)$. Notice that in reflecting across the y -axis, the change to each original point (x, y) can be represented by $(-x, y)$.

If you reflect $\triangle ABC$ across the x -axis to get $\triangle PQR$, then the new points are $P(5, -2)$, $Q(2, -4)$, and $R(4, -6)$. In this case, reflecting across the x -axis, the change to each original point (x, y) can be represented by $(x, -y)$.

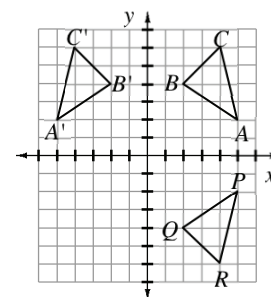

Example 4

Rotate (turn) $\triangle ABC$ with coordinates $A(2, 0)$, $B(6, 0)$, and $C(3, 4)$ 90° counterclockwise about the origin $(0, 0)$ to get $\triangle A'B'C'$ with coordinates $A'(0, 2)$, $B'(0, 6)$, and $C'(-4, 3)$. Notice that for this 90° counterclockwise rotation about the origin, the change to each original point (x, y) can be represented by $(-y, x)$.

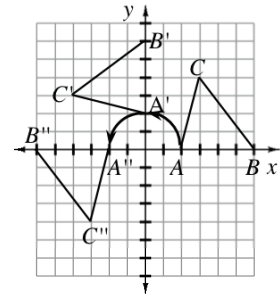

Rotating another 90° (180° from the starting location) yields $\triangle A''B''C''$ with coordinates $A''(-2, 0)$, $B''(-6, 0)$, and $C''(-3, -4)$.

For this 180° counterclockwise rotation about the origin, the change to each original point (x, y) can be represented by $(-x, -y)$. Similarly a 270° counterclockwise or 90° clockwise rotation about the origin takes each original point (x, y) to the point $(y, -x)$.

Problems

For each pair of triangles, describe the transformation that moves triangle A to the location of triangle B.

1.

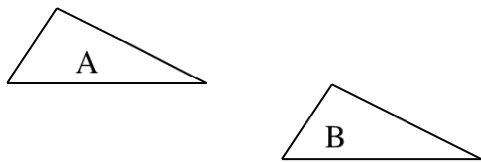

2.

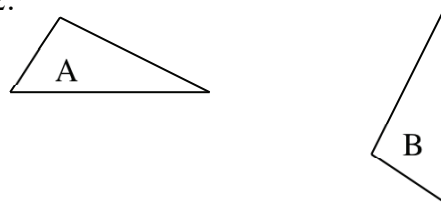

3.

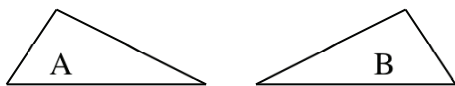

4.

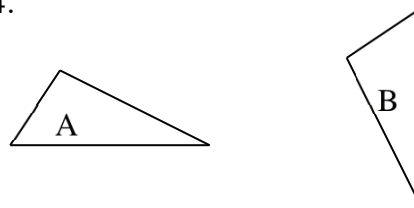

For the following problems, refer to the figures below:

Figure A

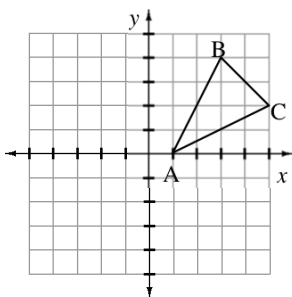

Figure B

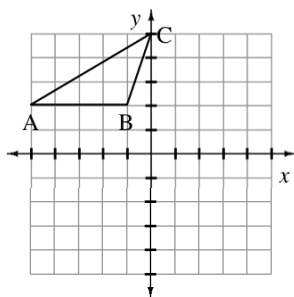
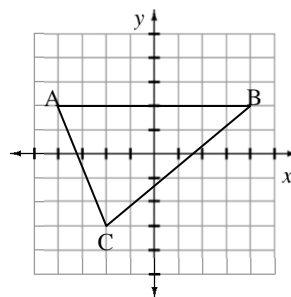

Figure C



State the new coordinates after each transformation.

5. Slide figure A left 2 units and down 3 units.
6. Slide figure B right 3 units and down 5 units.
7. Slide figure C left 1 unit and up 2 units.
8. Flip figure A across the x -axis.
9. Flip figure B across the x -axis.
10. Flip figure C across the x -axis.
11. Flip figure A across the y -axis.
12. Flip figure B across the y -axis.
13. Flip figure C across the y -axis.
14. Rotate figure A 90° counterclockwise about the origin.
15. Rotate figure B 90° counterclockwise about the origin.
16. Rotate figure C 90° counterclockwise about the origin.
17. Rotate figure A 180° counterclockwise about the origin.
18. Rotate figure C 180° counterclockwise about the origin.
19. Rotate figure B 270° counterclockwise about the origin.
20. Rotate figure C 90° clockwise about the origin.

Answers (1 – 4 may vary; 5–20 given in the order A', B', C')

- | | |
|-------------------------------------|------------------------------------|
| 1. translation | 2. rotation and translation |
| 3. reflection | 4. rotation and translation |
| 5. $(-1, -3)$ $(1, 2)$ $(3, -1)$ | 6. $(-2, -3)$ $(2, -3)$ $(3, 0)$ |
| 7. $(-5, 4)$ $(3, 4)$ $(-3, -1)$ | 8. $(1, 0)$ $(3, -4)$ $(5, -2)$ |
| 9. $(-5, -2)$ $(-1, -2)$ $(0, -5)$ | 10. $(-4, -2)$ $(4, -2)$ $(-2, 3)$ |
| 11. $(-1, 0)$ $(-3, 4)$ $(-5, 2)$ | 12. $(5, 2)$ $(1, 2)$ $(0, 5)$ |
| 13. $(4, 2)$ $(-4, 2)$ $(2, -3)$ | 14. $(0, 1)$ $(-4, 3)$ $(-2, 5)$ |
| 15. $(-2, -5)$ $(-5, 0)$ $(-2, -1)$ | 16. $(-2, -4)$ $(-2, 4)$ $(3, -2)$ |
| 17. $(-1, 0)$ $(-3, -4)$ $(-5, -2)$ | 18. $(4, -2)$ $(-4, -2)$ $(2, 3)$ |
| 19. $(2, 5)$ $(2, 1)$ $(5, 0)$ | 20. $(2, 4)$ $(2, -4)$ $(-3, 2)$ |

SIMILAR FIGURES

Two figures that have the same shape but not necessarily the same size are similar. In similar figures the measures of the corresponding angles are equal and the ratios of the corresponding sides are proportional. This ratio is called the scale factor. For information about corresponding sides and angles of similar figures see Lesson 4.1.1 in the *Core Connections, Course 2* text or the Math Notes box in Lesson 6.2.2 of the *Core Connections, Course 3* text. For information about scale factor and similarity, see the Math Notes boxes in Lesson 4.1.2 of the *Core Connections, Course 2* text or Lesson 6.2.6 of the *Core Connections, Course 3* text.

Example 1

Determine if the figures are similar. If so, what is the scale factor?

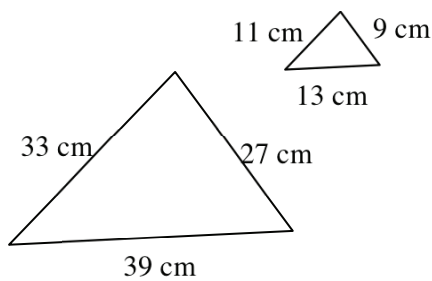

$$\frac{39}{13} = \frac{33}{11} = \frac{27}{9} = \frac{3}{1} \text{ or } 3$$

The ratios of corresponding sides are equal so the figures are similar. The scale factor that compares the small figure to the large one is 3 or 3 to 1. The scale factor that compares the large figure to the small figure is $\frac{1}{3}$ or 1 to 3.

Example 2

Determine if the figures are similar. If so, state the scale factor.

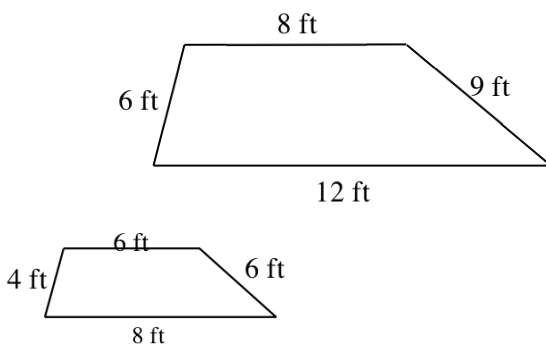

$$\frac{6}{4} = \frac{12}{8} = \frac{9}{6} \text{ and all equal } \frac{3}{2}.$$

$$\frac{8}{6} = \frac{4}{3} \text{ so the shapes are not similar.}$$

Example 3

Determine the scale factor for the pair of similar figures. Use the scale factor to find the side length labeled with a variable.

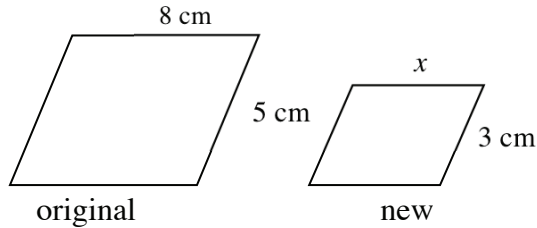

$$\text{scale factor} = \frac{3}{5}$$

$$\text{original} \cdot \frac{3}{5} \Rightarrow \text{new}$$

$$8 \cdot \frac{3}{5} = x; \Rightarrow x = \frac{24}{5} = 4.8 \text{ cm}$$

Problems

Determine if the figures are similar. If so, state the scale factor of the first to the second.

1.

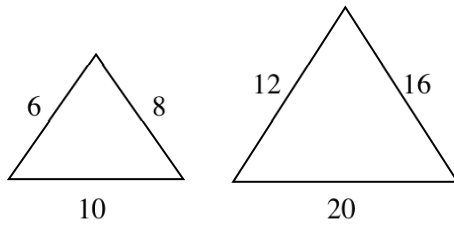

2. Parallelograms

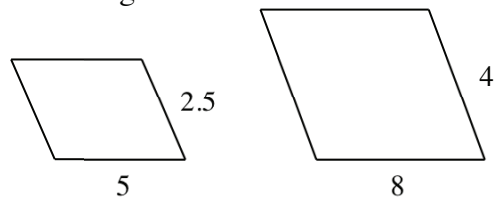

3. Kites

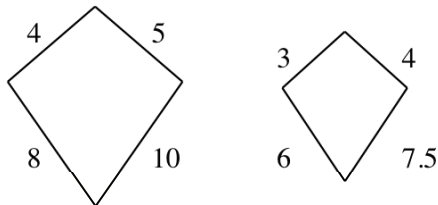

Determine the scale factor for each pair of similar figures. Use the scale factor to find the side labeled with the variable.

4.

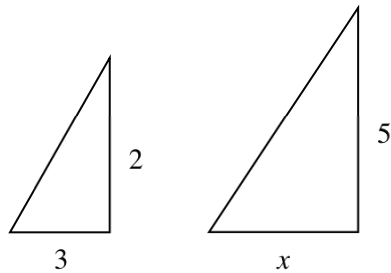

5.

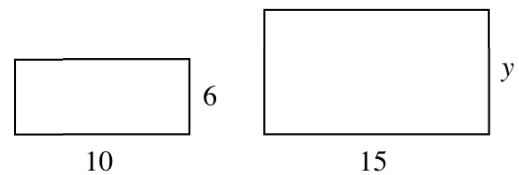

6.

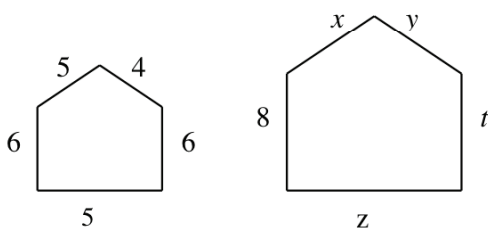

7.

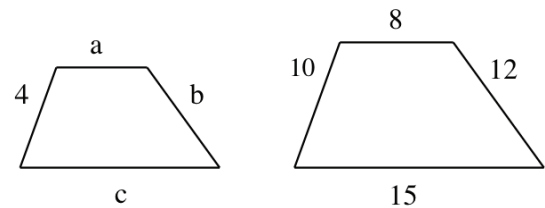

Answers

1. similar; 2 2. similar; $\frac{8}{5} = 1.6$ 3. not similar
4. $\frac{5}{2}$; $x = 7.5$ 5. $\frac{3}{2}$; $y = 9$
6. $\frac{4}{3}$; $x = \frac{20}{3} = 6\frac{2}{3}$, $y = \frac{16}{3} = 5\frac{1}{3}$, $t = 8$, $z = \frac{25}{3} = 8\frac{1}{3}$
7. $\frac{5}{2}$; $a = \frac{16}{5} = 3.2$, $b = \frac{24}{5} = 4.8$, $c = 6$

PYTHAGOREAN THEOREM

A right triangle is a triangle in which the two shorter sides form a right angle. The shorter sides are called legs. Opposite the right angle is the third and longest side called the hypotenuse.

The Pythagorean Theorem states that for any right triangle, the sum of the squares of the lengths of the legs is equal to the square of the length of the hypotenuse.

$$(\text{leg } 1)^2 + (\text{leg } 2)^2 = (\text{hypotenuse})^2$$

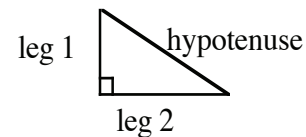
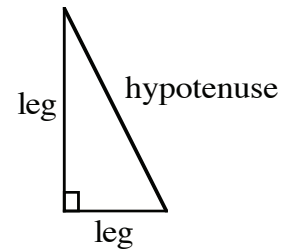

For additional information, see Math Notes box in Lesson 9.2.3 of the *Core Connections, Course 3* text.

Example 1

Use the Pythagorean Theorem to find x .

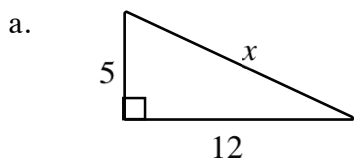

$$5^2 + 12^2 = x^2$$

$$25 + 144 = x^2$$

$$169 = x^2$$

$$13 = x$$

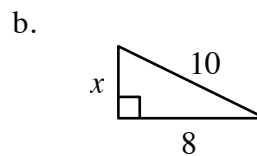

$$x^2 + 8^2 = 10^2$$

$$x^2 + 64 = 100$$

$$x^2 = 36$$

$$x = 6$$

Example 2

Not all problems will have exact answers. Use square root notation and your calculator.

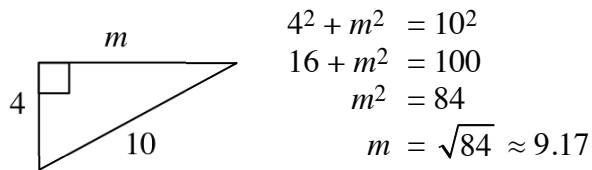

Example 3

A guy wire is needed to support a tower. The wire is attached to the ground five meters from the base of the tower. How long is the wire if the tower is 10 meters tall?

First draw a diagram to model the problem, then write an equation using the Pythagorean Theorem and solve it.

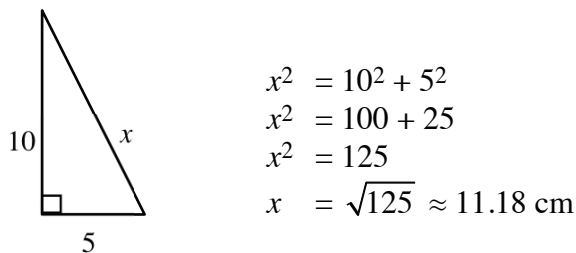

Problems

Write an equation and solve it to find the length of the unknown side. Round answers to the nearest hundredth.

1.

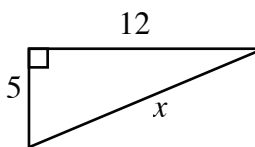

2.

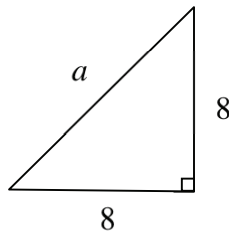

3.

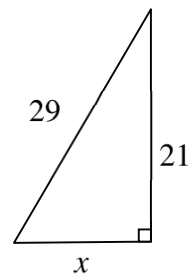

4.

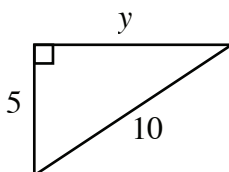

5.

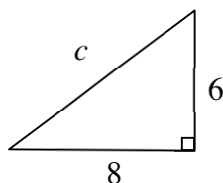

6.

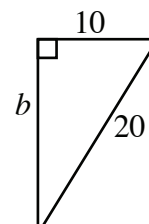

Draw a diagram, write an equation, and solve it. Round answers to nearest hundredth.

7. Find the diagonal of a television screen 30 inches wide by 35 inches tall.
8. A 9-meter ladder is one meter from the base of a building. How high up the building will the ladder reach?
9. Sam drove eight miles south and then five miles west. How far is he from his starting point?
10. The length of the hypotenuse of a right triangle is six centimeters. If one leg is four centimeters, how long is the other leg?
11. Find the length of a path that runs diagonally across a 55-yard by 100-yard field.
12. How long an umbrella will fit in the bottom of a suitcase 1.5 feet by 2.5 feet?

Answers

1. 13 2. 11.31 3. 20 4. 8.66 5. 10 6. 17.32
7. 46.10 in. 8. 8.94 m. 9. 9.43 mi 10. 4.47 cm 11. 114.13 yd 12. 2.92 ft

CYLINDERS – VOLUME AND SURFACE AREA

VOLUME OF A CYLINDER

The volume of a cylinder is the area of its base multiplied by its height:

$$V = B \cdot h$$

Since the base of a cylinder is a circle of area $A = r^2\pi$, we can write:

$$V = r^2\pi h$$

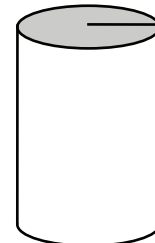

For additional information, see the Math Notes box in Lesson 10.1.2 of the *Core Connections, Course 3* text.

Example 1

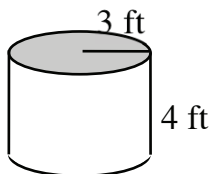

Find the volume of the cylinder above.
Use a calculator for the value of π .

$$\begin{aligned} \text{Volume} &= r^2\pi h \\ &= (3)^2\pi (4) \\ &= 36\pi \\ &= 113.10 \text{ ft}^3 \end{aligned}$$

Example 2

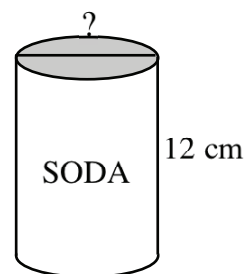

The soda can above has a volume of 355 cm^3 and a height of 12 cm. What is its diameter?
Use a calculator for the value of π .

$$\begin{aligned} \text{Volume} &= r^2\pi h \\ 355 &= r^2\pi (12) \\ \frac{355}{12\pi} &= r^2 \\ 9.42 &= r^2 \\ \text{radius} &= 3.07 \\ \text{diameter} &= 2(3.07) = 6.14 \text{ cm} \end{aligned}$$

Problems

Find the volume of each cylinder.

- | | | |
|--|---|---|
| 1. $r = 5 \text{ cm}$
$h = 10 \text{ cm}$ | 2. $r = 7.5 \text{ in.}$
$h = 8.1 \text{ in.}$ | 3. diameter = 10 cm
$h = 5 \text{ cm}$ |
| 4. base area = 50 cm^2
$h = 4 \text{ cm}$ | 5. $r = 17 \text{ cm}$
$h = 10 \text{ cm}$ | 6. $d = 29 \text{ cm}$
$h = 13 \text{ cm}$ |

Find the missing part of each cylinder.

7. If the volume is 5175 ft^3 and the height is 23 ft, find the diameter.
8. If the volume is $26,101.07 \text{ inches}^3$ and the radius is 17.23 inches, find the height.
9. If the circumference is 126 cm and the height is 15 cm, find the volume.

Answers

- | | | |
|--------------------------|---------------------------|-----------------------------|
| 1. 785.40 cm^3 | 2. 1431.39 in^3 | 3. 392.70 cm^3 |
| 4. 200 cm^3 | 5. 9079.20 cm^3 | 6. 8586.76 cm^3 |
| 7. 16.93 ft | 8. 28 inches | 9. $18,950.58 \text{ cm}^3$ |

SURFACE AREA OF A CYLINDER

The surface area of a cylinder is the sum of the two base areas and the lateral surface area.
The formula for the surface area is:

$$SA = 2r^2\pi + \pi dh \quad \text{or} \quad SA = 2r^2\pi + 2\pi rh$$

where r = radius, d = diameter, and h = height of the cylinder. For additional information, see the Math Notes box in Lesson 10.1.3 of the *Core Connections, Course 3* text.

Example 1

Find the surface area of the cylinder at right.
Use a calculator for the value of π .

Step 1: Area of the two circular bases

$$2[(8 \text{ cm})^2\pi] = 128\pi \text{ cm}^2$$

Step 2: Area of the lateral face

$$\pi(16)15 = 240\pi \text{ cm}^2$$

Step 3: Surface area of the cylinder

$$128\pi \text{ cm}^2 + 240\pi \text{ cm}^2 = 368\pi \text{ cm}^2 \\ \approx 1156.11 \text{ cm}^2$$

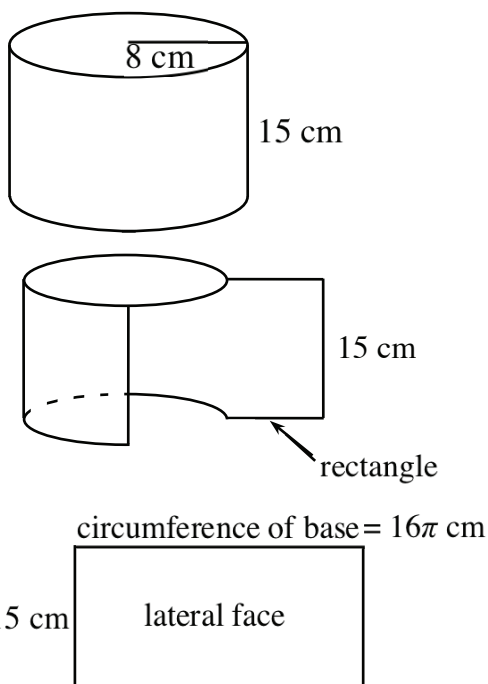

Example 2

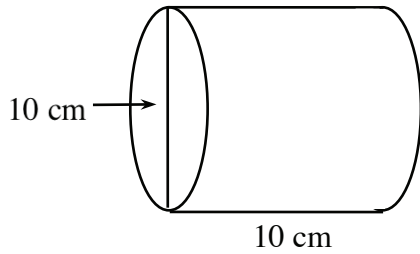

$$\begin{aligned}
 SA &= 2r^2\pi + 2\pi rh \\
 &= 2(5)^2\pi + 2\pi \cdot 5 \cdot 10 \\
 &= 50\pi + 100\pi \\
 &= 150\pi \approx 471.24 \text{ cm}^2
 \end{aligned}$$

Example 3

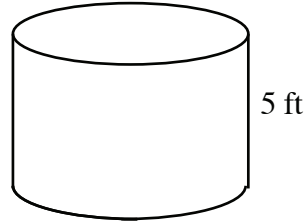

If the volume of the tank above is $500\pi \text{ ft}^3$, what is the surface area?

$$\begin{aligned}
 V &= \pi r^2 h \\
 500\pi &= \pi r^2 (5) \\
 \frac{500\pi}{5\pi} &= r^2 \\
 100 &= r^2 \\
 10 &= r
 \end{aligned}$$

$$\begin{aligned}
 SA &= 2r^2\pi + 2\pi rh \\
 &= 2 \cdot 10^2\pi + 2\pi(10)(5) \\
 &= 200\pi + 100\pi \\
 &= 300\pi \approx 942.48 \text{ ft}^2
 \end{aligned}$$

Problems

Find the surface area of each cylinder.

- | | | |
|---|--|---|
| 1. $r = 6 \text{ cm}, h = 10 \text{ cm}$ | 2. $r = 3.5 \text{ in.}, h = 25 \text{ in.}$ | 3. $d = 9 \text{ in.}, h = 8.5 \text{ in.}$ |
| 4. $d = 15 \text{ cm}, h = 10 \text{ cm}$ | 5. base area = 25,
height = 8 | 6. Volume = 1000 cm^3 ,
height = 25 cm |

Answers

- | | | |
|--------------------------|---------------------------|---------------------------|
| 1. 603.19 cm^2 | 2. 626.75 in.^2 | 3. 367.57 in.^2 |
| 4. 824.69 cm^2 | 5. 191.80 in.^2 | 6. 640.50 cm^2 |

PYRAMIDS AND CONES – VOLUME

The volume of a pyramid is one-third the volume of the prism with the same base and height and the volume of a cone is one-third the volume of the cylinder with the same base and height. The formula for the volume of the pyramid or cone with base B and height h is:

$$V = \frac{1}{3} Bh$$

For the cone, since the base is a circle the formula may also be written:

$$V = \frac{1}{3} r^2 \pi h$$

For additional information, see the Math Notes box in Lesson 10.1.4 of the *Core Connections, Course 3* text.

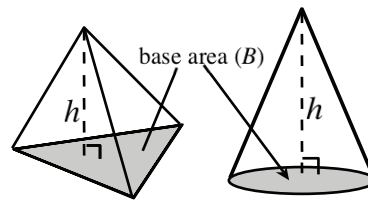

Example 1

Find the volume of the cone below.

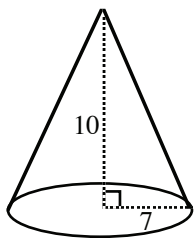

$$\begin{aligned} \text{Volume} &= \frac{1}{3} (7)^2 \pi \cdot 10 \\ &= \frac{490\pi}{3} \\ &\approx 513.13 \text{ units}^3 \end{aligned}$$

Example 2

Find the volume of the pyramid below.

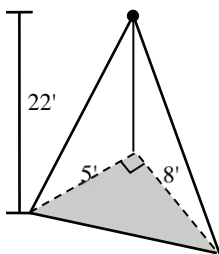

$$\begin{aligned} \text{Base is a right triangle} \\ B &= \frac{1}{2} \cdot 5 \cdot 8 = 20 \\ \text{Volume} &= \frac{1}{3} \cdot 20 \cdot 22 \\ &\approx 146.67 \text{ ft}^3 \end{aligned}$$

Example 3

If the volume of a cone is 4325.87 cm^3 and its radius is 9 cm, find its height.

$$\begin{aligned} \text{Volume} &= \frac{1}{3} r^2 \pi h \\ 4325.87 &= \frac{1}{3} (9)^2 \pi \cdot h \\ 12977.61 &= \pi(81) \cdot h \\ \frac{12977.61}{81\pi} &= h \\ 51 \text{ cm} &= h \end{aligned}$$

Problems

Find the volume of each cone.

1. $r = 4 \text{ cm}$
 $h = 10 \text{ cm}$

2. $r = 2.5 \text{ in.}$
 $h = 10.4 \text{ in.}$

3. $d = 12 \text{ in.}$
 $h = 6 \text{ in.}$

4. $d = 9 \text{ cm}$
 $h = 10 \text{ cm}$

5. $r = 6\frac{1}{3} \text{ ft}$
 $h = 12\frac{1}{2} \text{ ft}$

6. $r = 3\frac{1}{4} \text{ ft}$
 $h = 6 \text{ ft}$

Find the volume of each pyramid.

- | | | |
|---|---|--|
| 7. base is a square with side 8 cm
$h = 12$ cm | 8. base is a right triangle with legs 4 ft and 6 ft
$h = 10\frac{1}{2}$ ft | 9. base is a rectangle with width 6 in., length 8 in.
$h = 5$ in. |
|---|---|--|

Find the missing part of each cone described below.

10. If $V = 1000$ cm³ and $r = 10$ cm, find h .
11. If $V = 2000$ cm³ and $h = 15$ cm, find r .
12. If the circumference of the base = 126 cm and $h = 10$ cm, find the volume.

Answers

- | | | |
|---------------------------|---------------------------|-----------------------------|
| 1. 167.55 cm ³ | 2. 68.07 in. ³ | 3. 226.19 in. ³ |
| 4. 212.06 cm ³ | 5. 525.05 ft ³ | 6. 66.37 ft ³ |
| 7. 256 cm ³ | 8. 42 ft ³ | 9. 80 in. ³ |
| 10. 9.54 cm | 11. 11.28 cm | 12. 4211.24 cm ³ |

SPHERES – VOLUME

For a sphere with radius r , the volume is found using: $V = \frac{4}{3} \pi r^3$.

For more information, see the Math Notes box in Lesson 10.1.5 of the *Core Connections, Course 3* text.

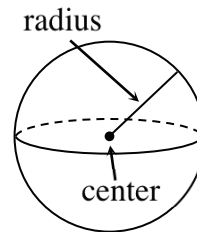

Example 1

Find the volume of the sphere at right.

$$V = \frac{4}{3} \pi r^3 = \frac{4}{3} \pi 2^3 = \frac{32\pi}{3} \text{ ft}^3 \text{ exact answer}$$

or using $\pi \approx 3.14$

$$\frac{32(3.14)}{3} \approx 33.49 \text{ ft}^3 \text{ approximate answer}$$

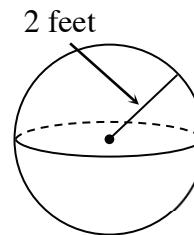

Example 2

A sphere has a volume of 972π . Find the radius.

Use the formula for volume and solve the equation for the radius.

$$V = \frac{4}{3} \pi r^3 = 972\pi$$

$$4\pi r^3 = 2916\pi$$

$$r^3 = \frac{2916\pi}{4\pi} = 729$$

$$r = \sqrt[3]{729} = 9$$

Substituting

Multiply by 3 to remove the fraction

Divide by 4π to isolate r .

To undo cubing, take the cube root

Problems

Use the given information to find the exact and approximate volume of the sphere.

- | | | |
|-----------------------|--|---|
| 1. radius = 10 cm | 2. radius = 4 ft | 3. diameter = 10 cm |
| 4. diameter = 3 miles | 6. circumference of great circle = 12π | 6. circumference of great circle = 3π |

Use the given information to answer each question related to spheres.

- If the radius is 7 cm, find the volume.
- If the diameter is 10 inches, find the volume.
- If the volume of the sphere is 36π , find the radius.
- If the volume of the sphere is $\frac{256\pi}{3}$, find the radius.

Answers

- | | |
|---|--|
| 1. $\frac{4000\pi}{3} \approx 4186.67 \text{ cm}^3$ | 2. $\frac{256\pi}{3} \approx 267.94 \text{ ft}^3$ |
| 3. $\frac{500\pi}{3} \approx 523.33 \text{ cm}^3$ | 4. $\frac{9\pi}{2} \approx 14.13 \text{ mi}^3$ |
| 5. $288\pi \approx 904.32 \text{ un}^3$ | 6. $\frac{9\pi}{2} \approx 14.13 \text{ un}^3$ |
| 7. $\frac{1372\pi}{3} \approx 1436.75 \text{ cm}^3$ | 8. $\frac{500\pi}{3} \approx 523.60 \text{ in.}^3$ |
| 9. $r = 3$ units | 10. $r = 4$ units |